

Multicolor Laser Pulse Synthesis with Attosecond Accuracy

- way to an optical function generator -

Yohei KOBAYASHI

Photonics Research
Institute
e-mail:
y.kobayashi@aist.go.jp
AIST Today Vol. 3, No.11
(2003) 15

We have controlled the optical phase (carrier-envelope-offset phase) relation between different-color femtosecond pulses that were generated by an optical parametric oscillator. The fluctuation of the cavity length difference between two laser oscillators causes the optical phase fluctuation. The cavity length fluctuates about 10 nm within a short time generally. It was reduced into attometer (1 attometer: 10^{-18} m) region when the optical-

phase-difference signal among multicolor femtosecond pulses was fed back to the cavity-length (figure). This feedback system suppressed the cavity-length fluctuation about ten orders of magnitude. By using this technique, we have generated phase-coherent multicolor femtosecond pulses. An optical parametric oscillator system generated six subharmonic femtosecond pulses in visible and infrared region with attosecond stability.

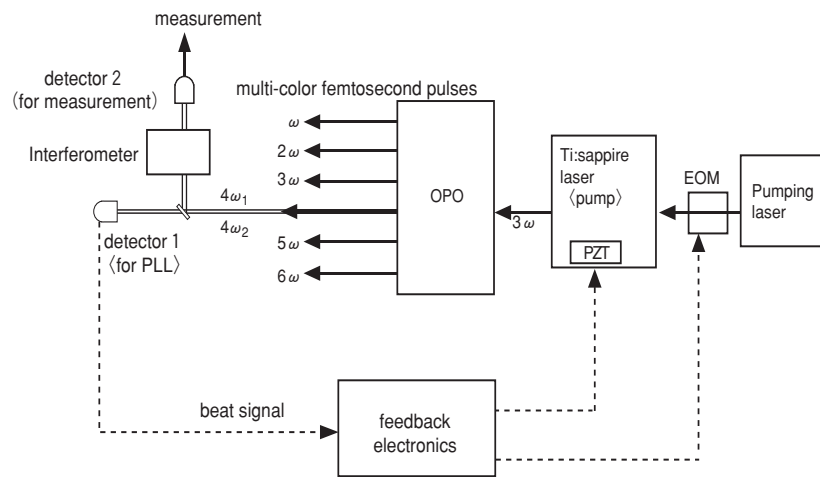

Schematic of the experimental setup

Automatic Alignment of Multiple Optical Devices

Masahiro MURAKAWA

Advanced Semiconductor
Research Center
e-mail:
m.murakawa@aist.go.jp
AIST Today Vol. 3, No.11
(2003) 16

We have developed, in collaboration with the Nano Control Co., Ltd., a system for automatic alignment (precision positioning) between multiple optical devices based on a genetic algorithm for the artificial intelligence, and succeeded in connecting wave guides with optical fiber arrays in a shortspan of time through the simultaneous alignment of input and output sides. Through the application of the present technology, it may be expected that the massive production of functional optical devices at lower cost will be realized, and the spread of the optical networks will be accelerated. Its application areas include not only the precision

alignment of optical devices, but also that for optical instruments, micro-fabrication and nano-technology.

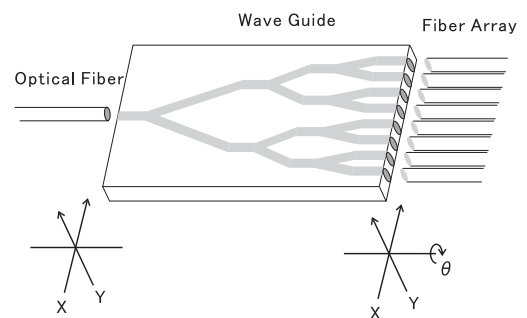

Alignment of optical fiber-wave guide-fiber array